



El Amarillo!!



HER Y FER TOOLS, S.A. DE C.V.

O Formões com carboneto de Tungstênio sua diferente aplicações:

C2

K68

DESBASTE DE FUNDIÇÃO COM GRANDE AVANÇAR E BAIXA VELOCIDADE CORTE ÚTIL USINAGEM DE: LIGAS DE ALTA RESISTÊNCIA MECÂNICA EM TEMPERATURAS ELEVADAS, COBRE, BRONZE E LIGAS LEVES; PERMITE MUITO GRANDES ÂNGULOS ADEQUADOS PARA ESCOVAÇÃO DE ATAQUE POSITIVO, ÚTIL NA USINAGEM DE AÇO DUREZA RC

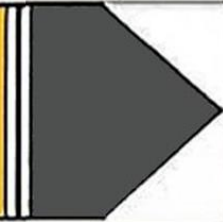

C6

K42

USINAGEM LEVE E DE AÇO DE ESPESSURA E MATERIAIS INOXIDÁVEIS COM VELOCIDADE DE CORTE E AVANÇO MODERADO APROPRIADO COPIAR PARA TORNEAMENTO E ENFIAR NO TORNO

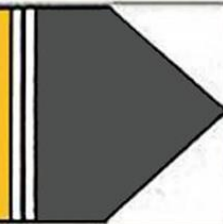

BURILES

TIPO AR Y AL

Buriles para cilindrar y barrenar

ESTILO	A	B	C
AR-4 AL-4	6.3 1/4"	6.3 1/4"	50.8 2"
AR-5 AL-5	7.9 5/16"	7.9 5/16"	57.1 2.1/4"
AR-6 AL-6	9.5 3/8"	9.5 3/8"	63.5 2.1/2"
AR-7 AL-7	11.1 7/16"	11.1 7/16"	76.2 3"
AR-8 AL-8	12.7 1/2"	12.7 1/2"	88.9 3.1/2"
AR-10 AL-10	15.8 5/8"	15.8 5/8"	101.6 4"
AR-12 AL-12	19.0 3/4"	19.0 3/4"	114.3 4.1/2"
AR-16 AL-16	25.4 1"	25.4 1"	178.0 7"

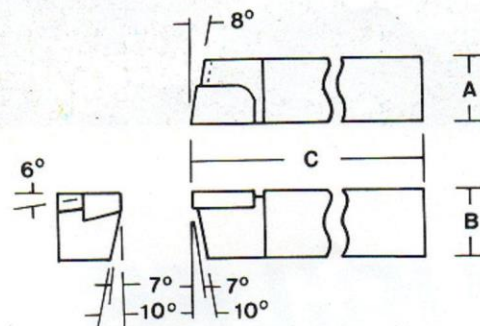
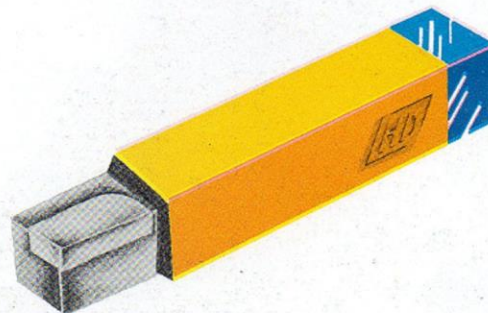



El Amarillo!!



HER Y FER TOOLS, S.A. DE C.V.

BURILES

CON INSERTO DE CARBURO DE TUNGSTENO

TIPO BR Y BL

Buriles para desbastar

ESTILO	A	B	C
BR-4 BL-4	6.3 1/4"	6.3 3/4"	50.8 2"
BR-5 BL-5	7.9 5/16"	7.9 5/16"	57.1 2-1/4"
BR-6 BL-6	9.5 3/8"	9.5 3/8"	63.5 2-1/2"
BR-7 BL-7	11.1 7/16"	11.1 7/16"	76.2 3"
BR-8 BL-8	12.7 1/2"	12.7 1/12"	88.8 3-1/2"
BR-10 BL-10	15.8 5/8"	15.8 5/8"	101.6 4"
BR-12 BL-12	19.0 3/4"	19.0 3/4"	114.3 4-1/2"
BR-16 BL-16	25.4 1"	25.4 1"	178.0 7"

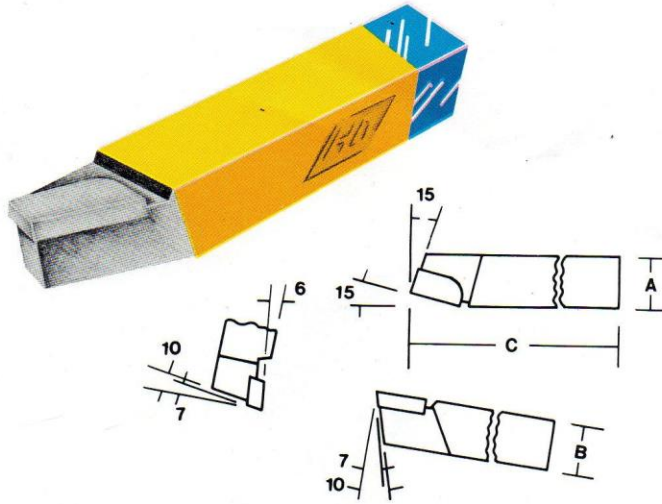

TIPO C

Buriles para herramientas de forma

ESTILO	A	B	C
C-4	6.4 1/4"	6.4 1/4"	50.8 2"
C-5	7.9 5/16"	7.9 5/16"	57.1 2-1/4"
C-6	9.5 3/8"	9.5 3/8"	63.5 2-1/2"
C-7	11.1 7/16"	11.1 7/16"	76.2 3"
C-8	12.7 1/2"	12.7 1/2"	88.9 3-1/2"
C-10	15.8 5/8"	15.8 5/8"	101.6 4"
C-12	19.0 3/4"	19.0 3/4"	114.3 4-1/2"
C-16	25.4 1"	25.4 1"	178.0 7"

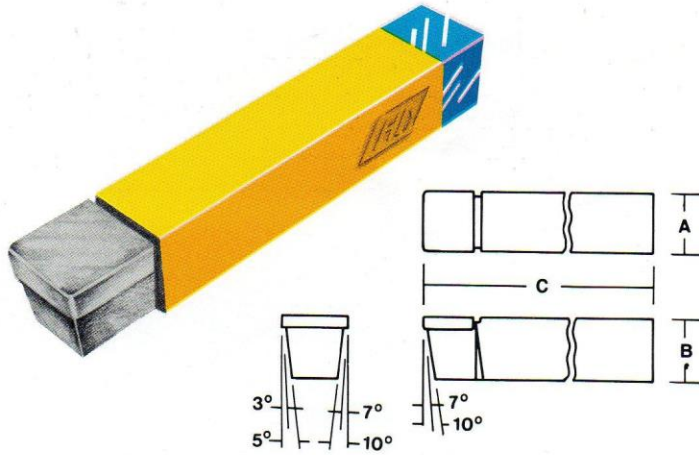

TIPO D

Buriles para acabado y perfilado

ESTILO	A	B	C
D-4	6.4 1/4"	6.4 1/4"	50.8 2"
D-5	7.9 5/16"	7.9 5/16"	57.1 2-1/4"
D-6	9.5 3/8"	9.5 3/8"	11.1 7/16"
D-7	11.1 7/16"	63.5 2-1/2"	76.2 3"
D-8	12.7 1/2"	12.7 1/2"	88.9 3-1/2"
D-10	15.8 5/8"	15.8 5/8"	101.6 4"
D-12	19.0 3/4"	19.0 3/4"	114.3 4-1/2"
D-16	25.4 1"	25.4 1"	177.8 7"

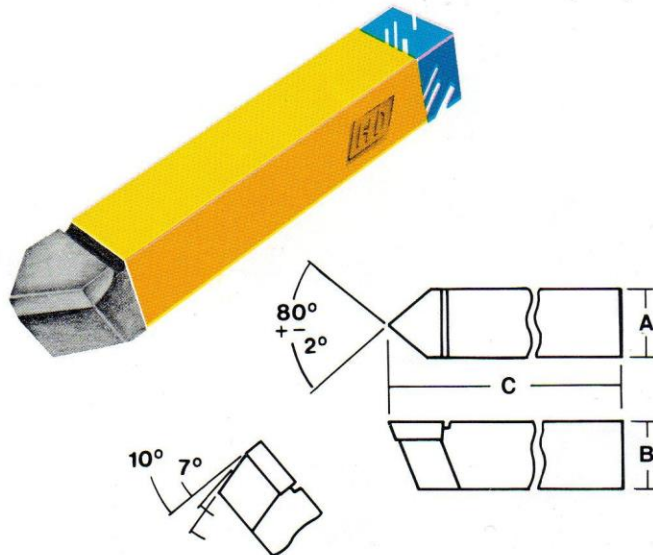



El Amarillo!!



HER Y FER TOOLS, S.A. DE C.V.

BURILES

CON INSERTO DE CARBURO DE TUNGSTENO

TIPO E

Buriles para roscar

ESTILO	A		B		C
E-4	6.3	1/4"	6.3	1/4"	50.8 2"
E-5	7.9	5/16"	7.9	5/16"	57.1 2.1/4"
E-6	9.5	3/8"	9.5	3/8"	63.5 2.1/2"
E-7	11.1	7/16"	11.1	7/16"	76.2 3"
E-8	12.7	1/2"	12.7	1/2"	88.9 3.1/2"
E-10	15.8	5/8"	15.8	5/8"	101.6 4"
E-12	19.0	3/4"	19.0	3/4"	114.3 4.1/2"

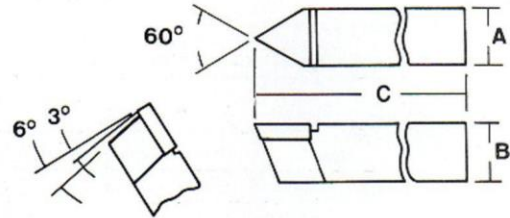
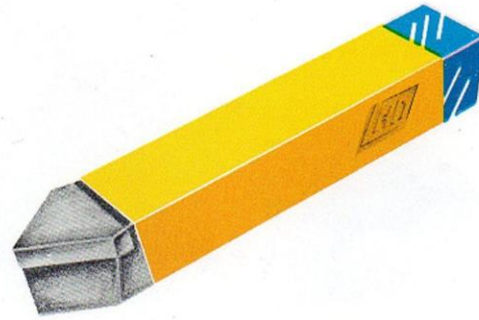

TIPO ER Y EL

ESTILO	A		B		C
	M/M	PULG.	M/M	PULG.	M/M PULG.
ER-5 EL-5	7.9	5/16"	7.9	5/16"	57.1 2.1/4"
ER-6 EL-6	9.5	3/8"	9.5	3/8"	63.5 2.1/2"
ER-8 EL-8	12.7	1/2"	12.7	1/2"	88.9 3-1/2"
ER-10 EL-10	15.8	5/8"	15.8	5/8"	101.6 4"
ER-12 EL-12	19.0	3/4"	19.0	3/4"	114.3 4.1/2"

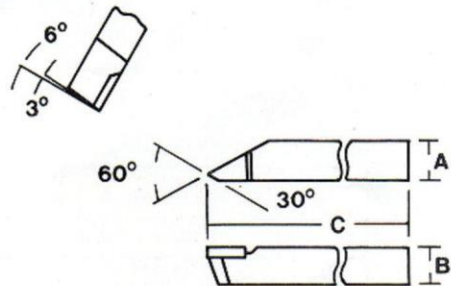



El Amarillo!!



HER Y FER TOOLS, S.A. DE C.V.

BURILES

CON INSERTO DE CARBURO DE TUNGSTENO

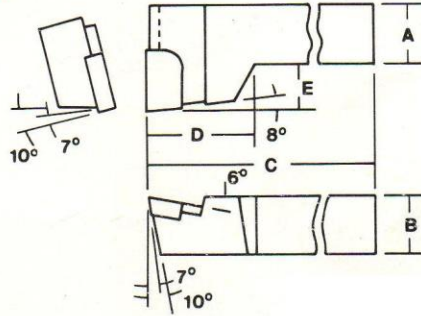
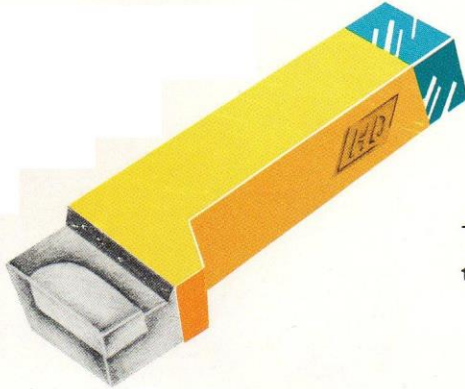

TIPO FR Y FL

Buriles para refrentar y esquinar

ESTILO	A		B		C		D		E	
	M/M	PULG.	M/M	PULG.	M/M	PULG.	M/M	PULG.	M/M	PULG.
FR- 8 FL-8	12.7	1/2"	12.7	1/2"	88.9	3.1/2"	19.0	3/4"	6.3	1/4"
FR-10 FL-10	15.8	5/8"	15.8	5/8"	101.6	4"	25.4	1"	9.5	3/8"
FR-12 FL-12	19.0	3/4"	19.0	3/4"	114.3	4-1/2"	28.6	1 1/8"	15.8	5/8"

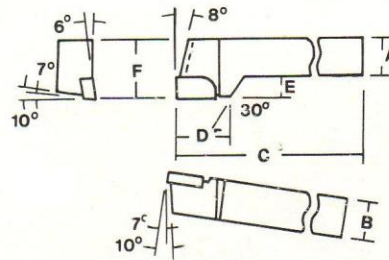
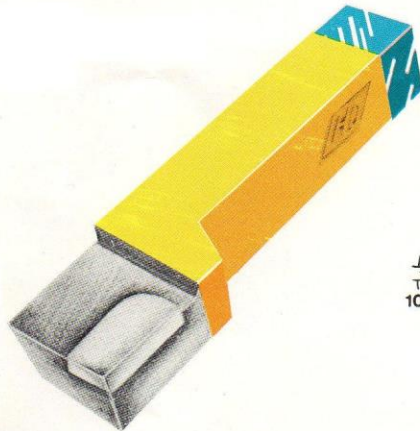

TIPO GR Y GL

Buriles para cilindrar y esquinar

ESTILO	A		B		C		D		E
	M/M	PULG.	M/M	PULG.	M/M	PULG.	M/M	PULG.	PULG.
GR-8 GL-8	12.7	1/2"	12.7	1/2"	88.9	3.1/2"	27.	1 1/16"	1/4
GR-10 GL-10	15.8	5/8"	15.8	5/8"	101.6	4"	34.9	1 3/8	3/8
GR-12 GL-12	19.0	3/4"	19.0	3/4"	114.3	4.1/2"	38.1	1 1/2	3/8



El Amarillo!!



HER Y FER TOOLS, S.A. DE C.V.

BURILES

CON INSERTO DE CARBURO DE TUNGSTENO

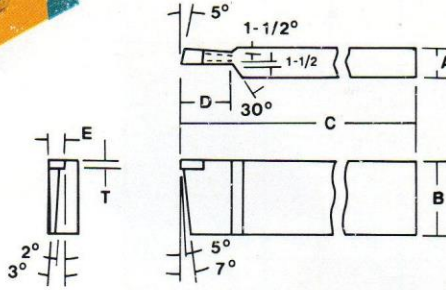
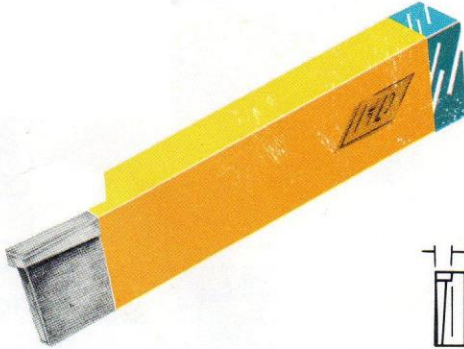

CUCHILLA DE CORTE CTR Y CTL

ESTILO	A		B		C		D		E	
	M/M	PULG.	M/M	PULG.	M/M	PULG.	M/M	PULG.	M/M	PULG.
CTR-120 CTL-120	12.7	1/2	25.4	1"	127.	5"	25.4	1"	7.9	5/16
CTR-121 CTL-121	12.7	1/2	25.4	1"	127.	5"	25.4	1"	6.3	1/4
CTR-122 CTL-122	12.7	1/2	25.4	1"	127.	5"	25.4	1"	4.7	3/16